

Please read this entire page. It concerns all 7^{5/8}" & 9^{5/8}" Vented Thru-tubing Bridge Plugs

Read this page before proceeding to NeoProducts' Recommended Best Practices for 7^{5/8}" & 9^{5/8}" T-TBPs.

Whenever running a 7^{5/8}" or 9^{5/8}" Neo vented metal petal thru-tubing bridge plug (NeoT-TBP) it is essential that WL operators be aware of the following:

Whenever running a 7^{5/8}" or 9^{5/8}" Neo vented T-TBP at service temperatures below 235° F, the metal petal basket can be destroyed if too much cmt slurry weight is placed atop the basket. The following operations are recommended when service temperatures are below 275° F.

When plugging-back in 7^{5/8}" or 9^{5/8}" csg using a vented T-TBP and WL dump bailing operations, the first dumped batch of cmt slurry must protect the metal petal basket. It must develop strength and bond to the csg before a second cmt slurry batch can be placed atop the first cmt slurry batch. It is mandatory that the first cmt dump run must be set and capable of supporting the weight of subsequent cmt slurry dump runs.

1. The 1st dump run should be 1-2 gallons of ceramic bridging aggregate or 20/40 mesh sand. Dump the aggregate/sand from 5 – 10 ft above the top on the vented T-TBP.
2. Locate the bottom of the cmt slurry bailer 3 ft above the metal petal basket and dump 3-5 gallons of 17 ppg NeoSuperSlurry atop the aggregate/sand,
3. If you do not accelerate the strength development and bonding of your cmt slurry to csg you must wait on cement before GIH with a 2nd NeoSuperSlurry cmt dump run as follows:
 - a. WOC 5 hrs if the temp at the basket is above 275° F, or
 - b. WOC 6 hrs if the temp at the basket is between 251°-275° F, or
 - c. WOC 7 hrs if the temp at the basket is between 226°-250° F, or
 - d. WOC 8 hrs if the temp at the basket is between 215°-225° F, or
 - e. WOC 9 hrs if the temp at the basket is between 201°-214° F, or
 - f. WOC 10 hrs if the temp at the basket is between 176°-200° F, or
 - g. WOC 15 hrs if the temp at the basket is between 161°-175° F, or
 - h. WOC 20 hrs if the temp at the basket is between 70°-160° F.

NeoProducts recommends that WL companies always load out with multiple Neo Accelerator Modifier Packs (P/N 0101-225-017) whenever dumping cmt slurry at service temperatures below 225° F.

4. If you accelerate the strength development of your cmt slurry, Neo Accelerator Modifier Packs can reduce WOC times by ~2-6 hrs, for example:
 - i. WOC 6 hrs if the temp at the basket is between 215°-225° F, or
 - ii. WOC 7 hrs if the temp at the basket is between 200°-214° F, or
 - iii. WOC 8 hrs if the temp at the basket is between 175°-199° F, or
 - iv. WOC 10 hrs if the temp at the basket is between 161°-174° F, or
 - v. WOC 12 hrs if the temp at the basket is between 150°-160° F, or
 - vi. WOC 15 hrs if the temp at the basket is between 70°-149° F.

Contact NeoProducts for more details on the subject matter above.

	Explosive Deployed NeoT-TBP Run-In Procedures	Date: 12/06/19	Page 1 of 14
		File Number: DRI-0163-0000	Rev. AL

NeoThru-TubingBridgePlug (NeoT-TBP)

Run & Set in Csg and Wellbore Brine Generic Run-in Procedures

Document # DRI-0163-0000

Recommended Operations to Maintain Static Wellbore Conditions

The operations below were strictly followed for many decades of high success rate Thru-tubing Plug-back Operations. Many WL operators are unaware of or have chosen to not perform these critical operations. Maintaining static wellbore conditions during Thru-Tubing Plug-back Operations is critical.

These are recommended procedures that will maintain a relatively static shut-in tubing pressure (SITP) and overall wellbore pressure when making multiple wireline (WL) & Slickline (SL) runs in and out of the well

1. Perform the lubricator pressure test using the appropriate water solution e.g., fresh water, brackish water, or weighted brine.
 - a. Use a 25% glycol/water solution if there is gas below the Master Valve (MV).
 - b. The pressure test should be at least 250 psi above the SITP.
2. Once the lubricator pressure test is finished, reduce the lubricator pressure to be 50-100 psig above the SITP.
3. Slowly crack open the MV and allow pressure equalization. Record the lubricator/wellhead SITP.
4. Descend into the well.
5. Monitor, record and adjust the wellhead pressure throughout descent and ascent operations. This must be done during every RIH until the plug is pressure tested.
 - a. Record the SITP before and after opening the MV on every RIH. Call this the recent SITP.
 - b. Maintain a constant wellhead pressure equal to the recent SITP ± 50 psig for that RIH.
 - i. Wellhead pressure can increase due to descending line displacement while RIH, bleed off wellhead pressure at the surface to maintain recent SITP ± 50 psig.
 - ii. Wellhead pressure can decrease due to ascending line displacement while coming out of the hole (COOH). Pump 25% glycol water solution into the wellhead to maintain the recent SITP ± 50 psig.
6. Perform a pressure test when and as instructed.

	Explosive Deployed NeoT-TBP Run-In Procedures	Date: 12/06/19	Page 2 of 14
		File Number: DRI-0163-0000	Rev. AL

Due Diligence

Thru-tubing plug-back operations can have a high success rate if the following principals are practiced:

- Read these recommended procedures prior to handling and running the plug.
- Use NeoSuperSlurry Cement Kits to achieve the desired long-term hydraulic isolation in the wellbore.
- If the plug is to be run in a sour/corrosive environment, special preparations and/or a specially designed plug may be necessary. Contact NeoProducts for more details.
- Set the plug at the desired depth.
- Locate the bottom of the first bailer run approximately 5 ft above the top of the plug and dump 1-2 gallons of ceramic aggregate from that location.
- Locate the bottom of the 2nd bailer run approximately 3 – 4 ft above the bailer stop and dump 3-5 gallons of cmt slurry atop the ceramic aggregate.
- WOC until the slurry is set (approximately 5 - 6 hrs) before dumping the second run of cement slurry. For 7-5/8" & 9-5/8" NeoT-TBPs, please refer to the first page or also Appendix A at the end of this document for special notes on dumping cement atop the 7-5/8" & 9-5/8" NeoT-TBP.
- Locate the bottom of the 3rd bailer run approximately 1-2 ft above the previously dumped cement and dump 4-5 gallons of cmt slurry.
- WOC an additional 3 hrs before GIH to make the remaining dump runs for the desired overall cmt plug length. This will allow the cement slurry to support all subsequent runs of cement.
- There is no sliding vent port that needs to get closed on the NeoT-TBPs, not including the 9-5/8" NeoT-TBPs. The 9-5/8" NeoT-TBPs do have the sliding vent port that does need to get closed.
- Wait a minimum of 18-24 hours after the last dump bailer run before pressure testing the cement plug.

The following well information and contingency preparations should be reviewed and recorded. Fill in the information below before running the NeoT-TBP in the well. Determine the following depths and write them in their space below;

	Explosive Deployed NeoT-TBP Run-In Procedures	Date: 12/06/19	Page 3 of 14
		File Number: DRI-0163-0000	Rev. AL

- a. the depth from the bottom of the plug to the top of the nearest perforations below the set plug _____.
- b. the approximate depth from the CCL on the toolstring to the nearest casing collar below the CCL _____.
- c. the approximate depth from the bottom of the plug to the next casing collar below the plug _____.
- d. the approximate depth from the top of the plug to the bottom of the nearest existing perforations above the plug _____.
- e. the approximate depth from the top of the plug to the bottom of the future nearest perforations above the plug _____.

PRE-PROJECT PREPARATION FOR A THRU-TUBING PLUG-BACK OPERATION

SAFETY NOTICE

Preparation and use of equipment must be performed in accordance with all applicable county, state, and federal requirements. All operations must comply with the safety requirements of the operating company, the on-site operating authority, and all involved service companies. Personnel handling explosives must be qualified in accordance with all applicable county, state, and federal requirements. Contact the on-site operations supervisor authority for advice if any problems arise or if service personnel encounter potentially unsafe circumstances.

Please confirm that the NeoT-TBP you are using is the correct size for your casing size. There is a label on the PVC tube that the NeoT-TBP is shipped in that shows the size and serial number of the NeoT-TBP.

The NeoT-TBP comes shipped as a vented plug. If you would like to make your NeoT-TBP a non-vented plug, simply thread the 1/4" NPT Pipe Plug that is supplied with your NeoT-TBP into the thread found on the bottom of the plug on the bull nose.

The following recommendations will help to achieve a successful plug-back. Although some of these recommendations might not be feasible, it is important that the Project Engineer be aware of their importance.

- a. If the well has a column of fluid to the surface and a positive shut-in tubing pressure, monitor and record the SITP before opening the Tree Master Valve prior to every run in the well. Successful plug-back projects require stable pressure maintenance at the plug setting depth throughout the plug-back project.
- b. Wells with a gas cap are much less sensitive to pressure maintenance during plug-back operations. A positive shut-in tubing pressure with a gas cap is common and not a serious concern.
- c. Determine if one of the following deleterious elements is present at the plug setting depth:

- | | | |
|--------------|---------------|-----------------|
| - oil | - natural gas | - scale |
| - condensate | - paraffin | - salt deposits |

Contact NeoProducts for consultation if any one of these damaging elements is present near the plug setting depth. Their presence can reduce or eliminate the bond between cement and casing. Oil and condensate will retard cement to the point where it takes weeks to set. When oil and/or condensate is present at the

	Explosive Deployed NeoT-TBP Run-In Procedures	Date: 12/06/19	Page 5 of 14
		File Number: DRI-0163-0000	Rev. AL

plug setting depth, dump 10 ppg NeoCasingCleaner to displace the hydrocarbon and remove the oil coating from the csg.

- d. If the well is on gas lift, bleed all pressure off the casing and tubing. If possible, pump brine into the well. Allow the well to stabilize for at least 24 hours prior to running the plug.
- e. Generally, it takes days for a wellbore to achieve pseudo-equilibrium. Fluid entering the wellbore and gas "percolating" into the wellbore can induce channels in a cement plug. Therefore, shut the well in and allow it to stabilize for at least 24 hours prior to running the plug. This will help to minimize the fluid and gas movement during plug-back operations.
- f. Run a stiff full length drift down to the plug setting depth. The drift should have the same run-in diameter and length as the dump bailer tool string.

RECOMMENDED PLUG-BACK OPERATIONS

KEEP THE SITP PRESSURE STATIC THROUGHOUT THE ENTIRE PLUG-BACK PROJECT

1. Inspect the wellhead upon arrival at the wellsite. Record the SITP. Pressure up the lubricator using brine or glycol/water to the SIP prior to opening the swab valve on every run throughout the entire plug-back project. Do this on every run.
2. Make a dummy gauge run. Include thermometers to measure the temperature at plug setting depth. Identify and record the top of fluid level. POOH.

CAUTION

The NeoT-TBP is spring loaded in the setting sleeve. IF MISHANDLED, THE PLUG COULD PREMATURELY EJECT AND CAUSE SERIOUS INJURY. Never stand in-line with the setting sleeve when loaded with a plug.
ALWAYS HANDLE NeoT-TBPs WITH CAUTION.

3. Make up the NeoT-TBP with a CCL. Refer to Figure 1A for tool string make-up.
4. Whenever the well deviation at the plug setting depth is greater than 30° run one or two bow spring centralizers at the top of the NeoT-TBP Setting Sleeve.
5. Regardless of deviation always run one or two bow spring centralizers and a minimum of 150 pounds of weight bars above 7-5/8" and 9-5/8" NeoT-TBPs.

NOTE: If a NeoT-TBP is run in the wellbore and not deployed for whatever reason, and is returned to the surface, do not re-run this plug. Run a back-up plug and return the original plug to NeoProducts for disposal.

	Explosive Deployed NeoT-TBP Run-In Procedures	Date: 12/06/19	Page 6 of 14
		File Number: DRI-0163-0000	Rev. AL

6. Run the **NeoT-TBP** in the hole. Once you are at depth, carefully tie in with casing collars. Locate the **NeoT-TBP** below the setting depth and slowly pull up, then;
 - a. Locate the bottom end of the **NeoT-TBP** at the depth that is one foot below the location where you want the cmt plug to begin,
 - b. Send power down the line and deploy the **NeoT-TBP**. The bottom end of the plug will extend one foot out the end of the Setting Sleeve. The top of the Metal-Pedal-Platform (the MPP) is now located at the point where you want the cmt plug to begin,
7. Closely monitor the line weight while looking for indications of slight line-weight changes once the **NeoT-TBP** setting operation is actuated.
8. Perform the following operations to verify that the plug is set in casing at the desired depth;
 - a. Pick up the toolstring 20' and stop.
 - b. Slowly descend until the setting sleeve sets down upon the **NeoBailerStop** which is just above the metal pedal platform. (If setting a 7-5/8" or 9-5/8" **NeoT-TBP**, do not descend onto the **NeoBailerStop** at this step. Continue pulling up the toolstring to surface)
 - c. The weight reading on the weight indicator will decrease if the plug is set in casing. For all plug sizes except for the 7-5/8" or 9-5/8" **NeoT-TBP**, slack-off 50-100 pounds.
 - d. Stop slacking-off if you are convinced that the plug is set and taking weight and go to 8j.
 - e. Continue to 8f if it appears that the plug is not taking weight.
 - f. Continue descending and stop descent once you see the next collar ring.
 - g. Discontinue operations and contact **NeoProducts** for technical support and the Operating Company for counsel. **NeoProducts** Tech Support is available 24/7.
 - h. The WL toolstring should not be pulled upward to a depth above the desired plug setting depth without the advice and consent of the Operating Company.
 - i. If you believe the plug is set, pick up to the next collar ring on your CCL and repeat Steps 8b – 8d.
 - j. If the plug takes weight POOH per standard safe practice.

Do not slack off weight again throughout the remainder of the project.

9. Make up the dump bailer system to dump bridging material. Strap the entire CCL/bailer assembly to be certain that you can accurately locate the bottom of the bailer approximately 5-10 feet above the top of the plug. GIH with enough bridging material to fill 1-2 feet of casing volume. (If dumping bridging material on a 7-5/8" or

	Explosive Deployed NeoT-TBP Run-In Procedures	Date: 12/06/19	Page 7 of 14
		File Number: DRI-0163-0000	Rev. AL

9-5/8" NeoT-TBP, dump 1-2 gallons of bridging material onto the basket) Locate the bailer 5-10 feet above the top of the plug and dump the bridging material. POOH.

The Bailer Stop Barrier on 5 1/2" and smaller NeoT-TBPs is located 18" below the vent valve (see Table on last page).

10. Make up the dump bailer to dump the cement slurry. The bailer should not be less than 1.69" (4.3cm). Strap the entire CCL/bailer assembly.
 - a. Fill the bailer with NeoSuperSlurry, a 17 ppg expanding High Shear Bond cement slurry, and GIH,
 - b. Reduce the rate of descent to 15 fpm (9,000 fph) once the bottom of the bailer is with 10 feet of the vent port,
 - c. Descend until the bailer is 1'-2' above the NeoBailerStop, see Table 1.
 - d. Dump the slurry,
 - e. Wait 1 minute, pick up 5 feet. Wait 1 minute, then
 - f. POOH.

WOC until the slurry is set (approximately 5 - 6 hrs) before dumping the second run of cement slurry.

REFER TO APPENDIX A FOR SPECIAL NOTES ON DUMPING CEMENT ATOP THE 7-5/8" or 9-5/8" NEOT-TBP.

For 7-5/8" & 9-5/8" NeoT-TBPs, once this initial slurry is set, proceed to tagging the plug by slowly descending onto the bailer stop or cement slurry. Slack off 50 pounds to ensure that the plug is at the desired location.

11. Redress the dump bailer.
 - a. Fill the bailer with NeoSuperSlurry, and GIH.
 - b. Reduce the rate of descent to 15 fpm (9,000 fph) once the bottom of the bailer is with 10 feet of the vent port.
 - c. Descend until the bailer bottom is 1 – 2 feet above the top of cmt or has reached the Bailer Stop Barrier, whichever comes first, stop,
 - d. Dump the slurry.
 - e. Wait 1 minute, then, pick up 5 feet. Wait a minute, then
 - f. POOH.
12. For vented NeoT-TBPs, repeat bailer runs until the cmt is within 12 inches to 18 inches of the vent port. For non-vented NeoT-TBPs, there is no need to worry about the vent valve and you can continue dumping cement.

	Explosive Deployed NeoT-TBP Run-In Procedures	Date: 12/06/19	Page 8 of 14
		File Number: DRI-0163-0000	Rev. AL

13. For vented NeoT-TBPs, the initial cmt plug is now in place. Wait at least 8 hours after the last dump bailer run before dumping the remaining recommended cement slurry. This will insure a properly cured and strong initial cmt plug.
14. Make up the dump bailer system needed to dump the remainder of the cement plug.
15. Fill the bailer with cmt. GIH, locate the bottom of the bailer 1 – 3 feet above the top of cmt. Dump the slurry. Dump as much NeoSuperSlurry as needed to achieve the desired plug length.
16. **Maintain static well conditions in the well. Wait at least 18-24 hours after the last bailer run before producing the well or performing a pressure test.**

Appendix A:

Please read this entire page. It concerns all 7^{5/8}" & 9^{5/8}" Vented Thru-tubing Bridge Plugs

Whenever running a 7^{5/8}" or 9^{5/8}" **Neo** vented metal petal thru-tubing bridge plug (**NeoT-TBP**) it is essential that WL operators be aware of the following:

Whenever running a 7^{5/8}" or 9^{5/8}" **Neo** vented T-TBP at service temperatures below 235° F, the metal petal basket can be destroyed if too much cmt slurry weight is placed atop the basket. The following operations are recommended when service temperatures are below 275° F.

When plugging-back in 7^{5/8}" or 9^{5/8}" csg using a vented T-TBP and WL dump bailing operations, the first dumped batch of cmt slurry must protect the metal petal basket. It must develop strength and bond to the csg before a second cmt slurry batch can be placed atop the first cmt slurry batch. It is mandatory that the first cmt dump run must be set and capable of supporting the weight of subsequent cmt slurry dump runs.

1. The 1st dump run should be 1-2 gallons of ceramic bridging aggregate or 20/40 mesh sand. Dump the aggregate/sand from 5 – 10 ft above the top on the vented T-TBP.
2. Locate the bottom of the cmt slurry bailer 3 ft above the metal petal basket and dump 3-5 gallons of 17 ppg **NeoSuperSlurry** atop the aggregate/sand,
3. If you do not accelerate the strength development and bonding of your cmt slurry to csg you must wait on cement before GIH with a 2nd **NeoSuperSlurry** cmt dump run as follows:
 - a. WOC 5 hrs if the temp at the basket is above 275° F, or
 - b. WOC 6 hrs if the temp at the basket is between 251°-275° F, or
 - c. WOC 7 hrs if the temp at the basket is between 226°-250° F, or
 - d. WOC 8 hrs if the temp at the basket is between 215°-225° F, or
 - e. WOC 9 hrs if the temp at the basket is between 201°-214° F, or
 - f. WOC 10 hrs if the temp at the basket is between 176°-200° F, or
 - g. WOC 15 hrs if the temp at the basket is between 161°-175° F, or
 - h. WOC 20 hrs if the temp at the basket is between 70°-160° F.

NeoProducts recommends that WL companies always load out with multiple **Neo** Accelerator Modifier Packs (P/N 0101-225-017) whenever dumping cmt slurry at service temperatures below 225° F.

4. If you accelerate the strength development of your cmt slurry, **Neo** Accelerator Modifier Packs can reduce WOC times by ~2-6 hrs, for example:
 - vii. WOC 6 hrs if the temp at the basket is between 215°-225° F, or
 - viii. WOC 7 hrs if the temp at the basket is between 200°-214° F, or
 - ix. WOC 8 hrs if the temp at the basket is between 175°-199° F, or
 - x. WOC 10 hrs if the temp at the basket is between 161°-174° F, or
 - xi. WOC 12 hrs if the temp at the basket is between 150°-160° F, or
 - xii. WOC 15 hrs if the temp at the basket is between 70°-149° F.

Contact **NeoProducts** for more details on the subject matter above.

	Explosive Deployed NeoT-TBP Run-In Procedures	Date: 12/06/19	Page 10 of 14
		File Number: DRI-0163-0000	Rev. AL

NeoT-TBP Tool String Make-Up for Explosive Setting Mechanism

Document # DPR-0163-0000

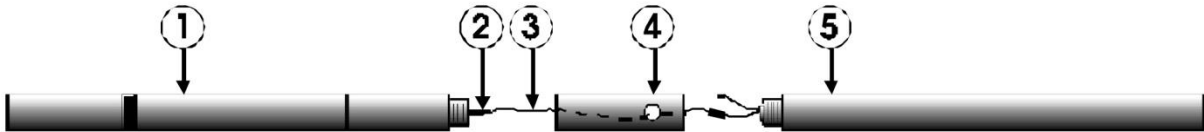
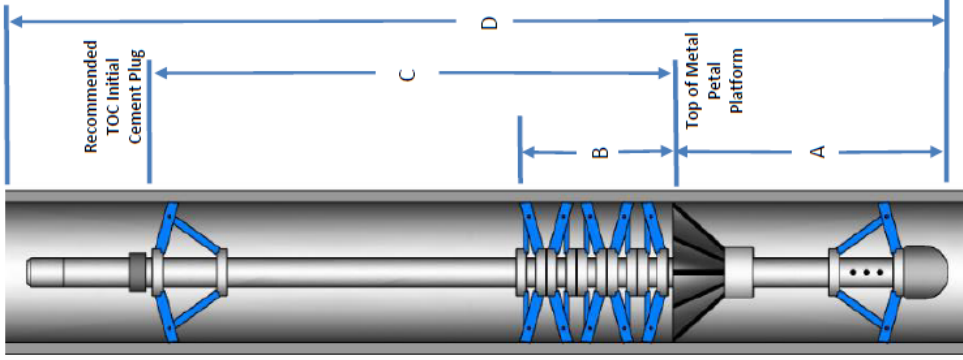

FIGURE 1A – NEOT-TBPTOOL STRING MAKE-UP - EXPLOSIVE SETTING MECHANISM

1. Check make-up of all threaded connections prior to leaving shop.
2. Make a "Pig-Tail" (Item 3) and connect it to the "hot" pin (Item 2) at the bottom of the firing head. The "Pig-Tail" should be long enough (8"-12") to stretch through the Neo Double Box Window Sub (Item 4). Place insulation over the electrical connection, ensure it is fluid tight (i.e., electrical tape, boot, etc.). Secure with seizing cord or clamp as appropriate.
3. Make up the EL Tool String (Item 1) to the Neo Double Box Window Sub. Stretch the "Pig-Tail" out the side window.
4. Insert an A-96L or equivalent detonator into the open hole at the very top of the plug. Push the detonator into the hole until it bottoms out. Secure the detonator with the special bolt provided.
5. Partially screw the Neo Setting Sleeve (Item 5) into the Double Box Window Sub. Direct the two leads of the detonator so that they extend out of the side window. Securely make up all threaded connections in the tool string. Do not place a wrench on the body of the setting sleeve more than 2" below the threaded end.
6. Cut the two leads of the detonator to length. Strip off the insulation to make the appropriate electrical connections.
7. Secure the ground lead from the detonator to the ground screw in the Double Box Window Sub. Complete the "hot" "Pig-Tail" connection and secure the fluid tight boot over the connection. Place the wires into the window sub and insure that they cannot extend out of the window while RIH.
8. The plug is now ready to be RIH.

	Explosive Deployed NeoT-TBP Run-In Procedures	Date: 12/06/19	Page 11 of 14
		File Number: DRI-0163-0000	Rev. AL

NeoT-TBP Dimensions (Vented & Non-Vented*)



NeoProducts Vented Thru-Tubing Bridge Plug (NeoT-TBP)						
NeoT-TBP API Csg Size	Sets in this API Csg Wgt Range	P/N	Plug Dimensions			
			A	B	Recommended Initial Cmt Plug	D
2 3/8" - 4"	all weights (this is a NeoWideRange T-TBP)	0163-238-400-001-S1 1 5/8" Run-In Diameter	34 3/4"	N/A	21"	73 1/2" (6 ft-1.5in.)
4 1/2" - 7"	all weights (this is a NeoWideRange T-TBP)	0163-450-700-001-S2 1 5/8" Run-In Diameter 0175-450-700-001-S2 1 3/4" Run-In Diameter	30"	19"	121.5" (10 ft-1.5in)	176" (14 ft-8in)
7 5/8"	all weights	0163-763-001 1 5/8" Run-In Diameter 0175-763-001 1 3/4" Run-In Diameter	30"	19"	121.5" (10 ft-1.5in)	176" (14 ft-8in)

Where to Position the NeoT-TBP to Accurately Place the Bottom of the Initial Cmt Plug

The NeoT-TBP is placed in a spring loaded Setting Sleeve. When the plug is deployed it slides 12" - 18" out the bottom of the Setting Sleeve. In order to accurately place the Metal-Petal-Platform you must position the bottom of the plug 1 ft below the depth where you want the bottom of your cmt plug. Fire the release tool and the top of the Metal-Petal-Platform will be at the desired depth. The top of the Metal-Petal-Platform establishes the bottom of the cmt plug.

* Non-vented NeoT-TBPs have the same dimensions as the Vented NeoT-TBPs shown above, and they are available off the shelf

** NeoProducts makes custom length and custom casing diameter NeoT-TBPs (contact NeoProducts for more information)

NeoProducts, LLC - 1201 Dealers Ave - Harahan, LA 70123
 Office: (504) 731-1011 · info@NeoProducts.net
 www.NeoProducts.net



9-5/8" NeoT-TBP Dimensions (Vented & Non-Vented*)

NeoProducts Vented Thru-Tubing Bridge Plug (NeoT-TBP)					
NeoT-TBP API Csg Size	Sets in this API Csg Wgt Range	P/N	Plug Dimensions		
			A	B	C
9 5/8"	all weights	0200-963-001 2" Run-In Diameter	35.75"	55"	180" (15 ft)
		0213-963-001 2 1/8" Run-In Diameter			
		0225-963-001 2 1/4" Run-In Diameter			
Where to Position the NeoT-TBP to Accurately Place the Bottom of the Initial Cmt Plug					

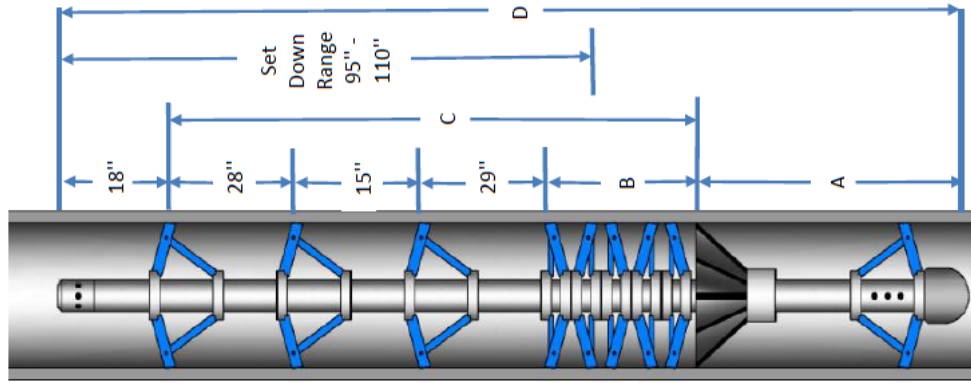

* Non-vented NeoT-TBPs have the same dimensions as the Vented NeoT-TBPs shown above, and they are available off the shelf

** NeoProducts makes custom length and custom casing diameter NeoT-TBPs (contact NeoProducts for more information)

*** 9-5/8" NeoT-TBPs will have the Sliding Vent System (no Tortuous Path). The sliding vent is located ~ 1" above Dimension C.

**** There should only be approximately 4.5-6 gallons of initial cement placed atop the basket. This cement must cure before adding any additional cement weight on the plug. See special 9-5/8" notes from NeoProducts.

The NeoT-TBP is placed in a spring loaded Setting Sleeve. When the plug is deployed it slides 12" - 18" out the bottom of the Setting Sleeve. In order to accurately place the Metal-Petal-Platform you must position the bottom of the plug 1 ft below the depth where you want the bottom of your cmt plug. Fire the release tool and the top of the Metal-Petal-Platform will be at the desired depth. The top of the Metal-Petal-Platform establishes the bottom of the cmt plug.

NeoProducts, LLC • 1201 Dealers Ave • Harahan, LA 70123
 Office: (504) 731-1011 • info@NeoProducts.net
 www.NeoProducts.net



Short NeoT-TBP Dimensions (Vented & Non-Vented*)

NeoProducts Vented Thru-Tubing Bridge Plug (NeoT-TBP)		P/N	Plug Dimensions			
NeoT-TBP API Csg Size	Sets in this API Csg Wgt Range		A	B	C Recommended Initial Cmt Plug	D
2 3/8" - 4"	all weights (this is a NeoWideRange T-TBP)	0163-238-400-005-S1 1 5/8" Run-In Diameter	34 3/4"	N/A	21"	73 1/2" (6 ft 1.5in.)
		0163-450-700-005-S2 1 5/8" Run-In Diameter	31"	18"	42"	100 1/2" (8 ft 4.5in.)
4 1/2" - 7"	all weights (this is a NeoWideRange T-TBP)	0175-450-700-005-S2 1 3/4" Run-In Diameter	31"	18"	42"	100 1/2" (8 ft 4.5in.)
		0163-763-005 1 5/8" Run-In Diameter	31"	18"	42"	100 1/2" (8 ft 4.5in.)
7 5/8"	all weights	0200-963-005 2" Run-In Diameter	30"	68"	*** 18" (1 ft-6 in)	130" (10 ft 10in.)
		0213-963-005 2 1/8" Run-In Diameter	30"	68"	*** 18" (1 ft-6 in)	130" (10 ft 10in.)
9 5/8"	all weights	0225-963-005 2 1/4" Run-In Diameter	30"	68"	*** 18" (1 ft-6 in)	130" (10 ft 10in.)

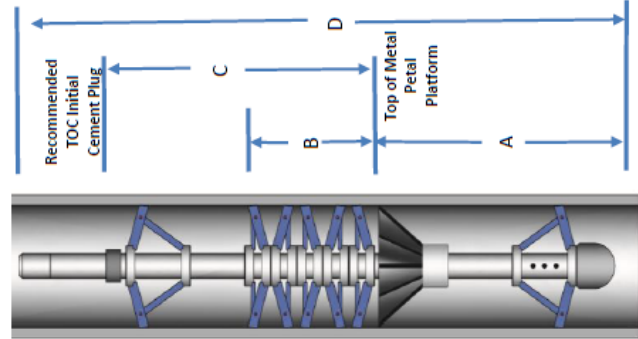

Where to Position the NeoT-TBP to Accurately Place the Bottom of the Initial Cmt Plug

The NeoT-TBP is placed in a spring loaded Setting Sleeve. When the plug is deployed it slides 12" - 18" out the bottom of the Setting Sleeve. In order to accurately place the Metal-Petal-Platform you must position the bottom of the plug 1 ft below the depth where you want the bottom of your cmt plug. Fire the release tool and the top of the Metal-Petal-Platform will be at the desired depth. The top of the Metal-Petal-Platform establishes the bottom of the cmt plug.

* Non-vented NeoT-TBPs have the same dimensions as the Vented NeoT-TBPs shown above

** NeoProducts makes custom length and custom casing diameter NeoT-TBPs (contact NeoProducts for more information)

*** There should only be approximately 4.5-6 gallons of initial cement placed atop the basket. This cement must cure before adding any additional cement weight on the plug. See special 9-5/8" notes from NeoProducts.

NeoProducts, LLC • 1201 Dealers Ave • Harahan, LA 70123
 Office: (504) 731-1011 • info@NeoProducts.net
 www.NeoProducts.net

